

## AR100 Laser Measurement Sensor

### Principles of Operation

The AR100 is a triangulation sensor that measures distance by projecting a beam of laser light that creates a spot on a target surface. Reflected light from the surface is viewed from an angle by a CMOS detector array inside the AR100 sensor. The target's distance is calculated from the image pixel data using the sensor's microprocessor. The distance is transmitted through serial communications, and analog outputs. A variety of models are specified, each to allow a different measurement range and standoff.

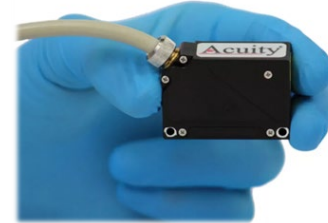

### Definitions

**Base Distance:** Offset distance from the face of the sensor to the beginning of the measurement edge. Accuracy is greatest at the middle of the range, and the laser spot size is the smallest at the middle of the measurement range.

**Range:** Working distance between measurement endpoints over which the sensor will reliably measure displacement.

**Linearity:** The largest deviation from a best-fit straight line over the measurement range, created by data from the sensor with reference taken from a true distance scale. Stated as  $\pm\%$  of the Range.

**Resolution:** Smallest change in distance that a sensor can detect. Stated as  $\%$  of the full-scale range.

**Sample Rate:** Speed that data samples are obtained from the sensor.

Model AR100	-10	-25	-50	-100	-250	500
Base distance X, mm	20	20	30	55	65	105
Range, mm	10	25	50	100	250	500
Linearity (digital), %	$\pm 0.05\%$ of the Full-Scale range				$\pm 0.1\%$	
Linearity (analog), %	0.1% of the range					
Resolution, %	0.01 % of the Full-Scale range (for digital output)					0.02%
Temperature drift	0.02% range/°C					
Maximal sampling rate, Hz	9,400 Hz					
Light source	Red semiconductor laser, 660 nm wavelength or UV semiconductor laser 405 nm wavelength (BLUE version)					
Output power, mV	$\leq 1$					
Laser Safety Class	2 (IEC60825-1)					
Output Interface	Digital	RS232 (max. 460.8 kbit/s) or RS485 (max. 460.8 kbit/s)				
	Analog	4- 20 mA (load $\leq$ 500 Ohm) or 0-10 Volts				
Trigger input	2.4 - 24 V (CMOS, TTL)					
Logical output	Programmed functions, NPN: 100 mA max; 40 V max for output					
Power supply, V	24 (9 - 36) Volts					
Power consumption, W	1.5 - 2.0 Watts					
Environmental Resistance	Enclosure rating	IP67				
	Vibration	20g/10 ... 1000Hz, 6 hours, for each of XYZ axes				
	Shock	30 g / 6 ms				
	Operation temperature, °C	-10 - +50 °C				
	Permissible Ambient light, lx	10,000				
	Relative humidity	5-95% (no condensation)				
	Storage temperature	-20 - +60, °C				
Housing material	aluminum, glass windows					
Weight (without cable)	40 grams					
Size, mm	17x45x30.5					

## AR100 Laser Measurement Sensor

Dimensions,  
mm [inches]

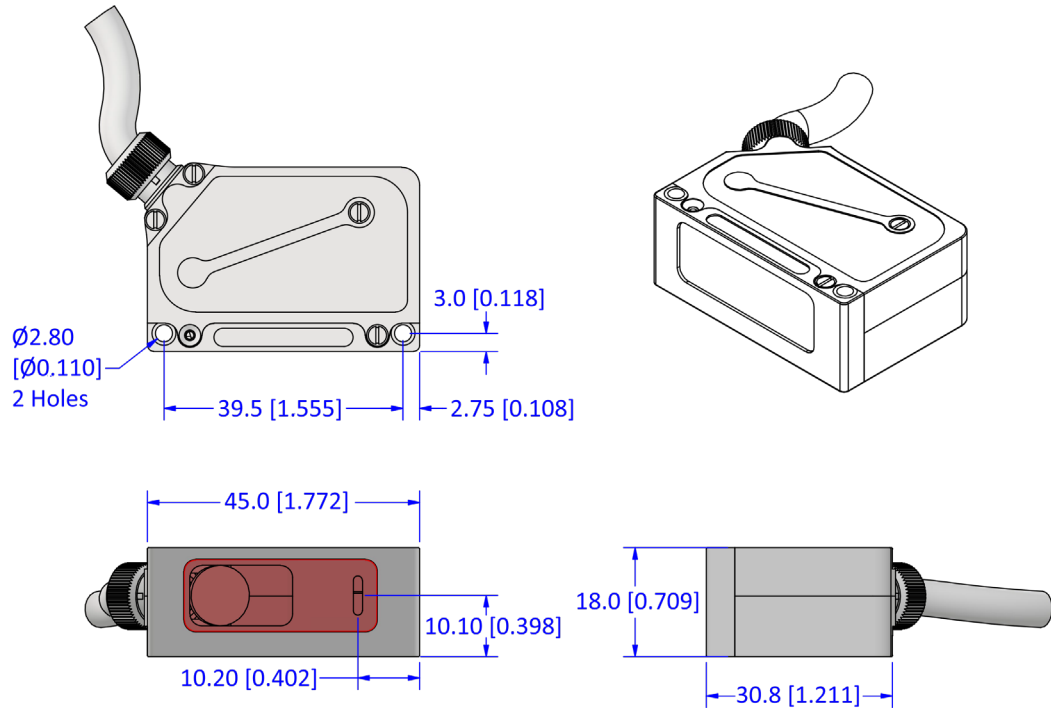

### AR100 Sensor Options

**Diode Options:** Can be purchase with a Class 2, eye-safe laser (< 1mW) in either red (660 nm) or blue (405 nm)

**Cables:** optional, longer cables. Contact us for custom cabling needs. Analog interface: Optional 0-10 V analog signal. Replaces 4-20mA signal.

**Connectivity kit:** Includes terminal blocks, serial cable with DB9 connector or serial to USB cable, AC power supply with 110 VAC or 240 VAC.

### Safety Labels

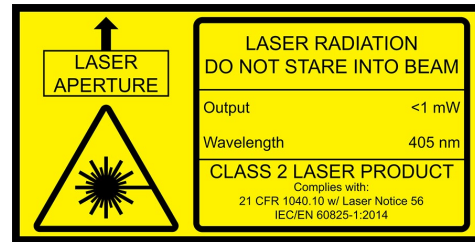
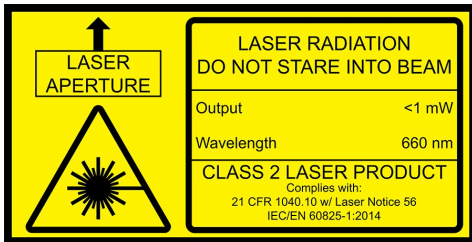

**Acuity**

© 2024  
A product line of Schmitt Measurement Systems, Inc.  
8000 NE 14th Place, Portland, Oregon, 972101, USA  
Tel: 503.210.5733 | Fax: (503) 223-1258 | [acuitylaser.com](http://acuitylaser.com)