



The **AR500** laser position sensors are compact devices for dimensional measurement. The unit uses laser triangulation principles to accurately measure at high speeds. The same compact enclosure houses models with ranges from 5 to 1000 mm. Sensor options include blue laser diodes, multiple analog output formats, and cooling jackets.

AR500 High Speed Laser Sensor

Principles of Operation

The **AR500** is a triangulation sensor that measures distance by projecting a beam of laser light that creates a spot on a target surface. Reflected light from the surface is viewed from an angle by a CMOS detector array inside the AR500 sensor. The target's distance is calculated from the image pixel data using the sensor's microprocessor. The distance is transmitted through serial communications, analog outputs or optionally, via Ethernet. A variety of models are specified, each to allow a different measurement range and standoff.



Definitions

Range: Working distance between measurement endpoints over which the sensor will reliably measure displacement.

Base Distance: Offset distance from the face of the sensor to the beginning of the measurement range. Accuracy is greatest at the middle of the range, and the laser spot size is the smallest at the middle of the measurement range.

Resolution: Smallest change in distance that a sensor can detect. Stated as % of the full-scale range.

Linearity: The largest deviation from a best-fit straight line over the measurement range, created by data from the sensor with reference taken from a true distance scale. Stated as a +/- % of the range.

Sample Rate: Speed that data samples are obtained from the sensor. The maximum attainable sample rate is determined by the selected operating mode and target reflectance.

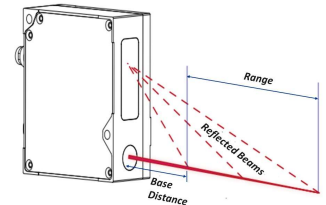

AR500 Standard Model Specifications Specifications in metric units. [English units in brackets]

AR500 Model	-5	-10	-25	-50	-100	-250	-500	-750	-1000	
Range mm [in.]	5 [0.20]	10 [0.39]	25 [0.98]	50 [1.97]	100 [3.94]	250 [9.84]	500 [19.7]	750 [29.5]	1000 [39.4]	
Base Distance mm [in.]	10 [0.39]	25 [0.98]	45 [1.77]	65 [2.55]	90 [3.54]	80 [3.15]	125 [4.95]	145 [5.75]	245 [9.6]	
Linearity (+/-) μm [10^{-3} in.]	0.10% of range								0.15%	
Resolution (+/-) μm [10^{-3} in.]	0.01% of range								0.02%	
Laser Spot Size μm	40	50	60	80	70	130	140	300	500	
Weight w/o Cable g [oz.]	100 grams [3.5 ounces]									
Available Laser Class	Class 2 (< 0.95 mW)									
	Class 3R (< 5 mW)									
							Class 3B (< 20 mW)			
Laser Color	Complies with 21 CFR 1040 with Laser Notice #50 and IEC/EN 60825-1:2014									
Power	RED Laser: 660 nm wavelength OR BLUE Laser: 405/450 nm wavelength									
Sample Rates	9 - 36 Volts DC, 250 mA max. Voltage tolerance -5% to +10%									
Operating Temp	Up to 9400 Hz, or sample trigger (serial command or input trigger wire)									
Environmental	-10 - 60°C [14 - 140°F]; to -30°C with optional heater; to 120°C with optional air-cooling; 95% Humidity (non-condensing)									
Shock/Vibration	NEMA - 4X, IP67. Keep optical windows clean for best performance. Aluminum case. Compliant with the RoHS directive regarding the reduction of the use of lead and other hazardous substances									
Temp. Drift	Shock: 30 g / 6 ms; Vibration: 20 g / 10...1000Hz, 6 hours, for each of XYZ axes									
Interfaces	0.02% of range / °C									
	Serial	STANDARD: RS232 full duplex (460.8 Kbits/sec); OPTION: RS485								
	Analog	STANDARD: 4-20 mA; OPTION: 0-10V								
	Ethernet	OPTION: Ethernet (minimum quantity order required)								
	Logic	STANDARD: Programmable (see manual), NPN: 100 mA max; 40 V max for output								
Sync. Trig.	STANDARD: 2.4 - 5 V (CMOS, TTL)									
Cable	length: 6 ft. (1.8 m), weight: 5.8 oz. (165 g), 12 conductor, Polyurethane sheathing. Binder 712 connector.									

Mechanical Dimensions units in mm.

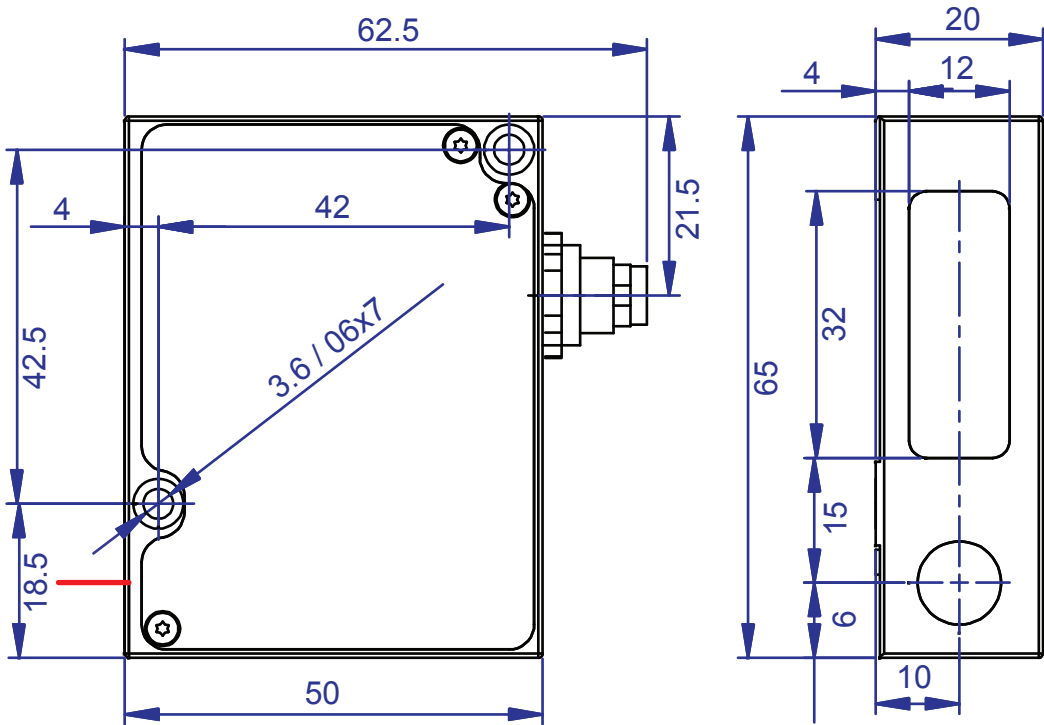

AR500 Sensor Options

- Connectivity kit:** Includes terminal blocks, serial cable with molded DB9 connector, AC power supply with 110 VAC or 240 VAC
- High power lasers:** Diode upgrades to visible red or blue for high sample rates on dark surfaces or in high ambient light.
- Cables:** Optional, longer cables. Contact us for custom cabling needs.
- Serial interface:** Optional RS485 interface for long-distance connections. Replaces RS232.
- Analog interface:** Optional 0-10 V analog interface signal. Replaces 4-20mA signal
- Internal heater:** Permits sensor use to -30°C
- Air-cooled jacket:** Enclosure with forced air to cool sensor for use up to 120°C. Sensor must be calibrated inside jacket at factory.
- Spray guard:** Open-sided enclosure which helps to keep debris off optical windows.

Laser Safety Labels

